

MasterSheet

050 0026
Revision 05/23/05



**1995-
Subaru Legacy**
Also pertains to:
Outback and 2.5 GT Sedan

IMPORTANT

Before starting, compare items on your invoice with items received. Carefully check through packaging material. If any item is missing, please call **Crutchfield Technical Service at 1-800-955-9094**.

Although reasonable attempts are made to verify the accuracy of the information contained in this MasterSheet, it is presented without warranties or guarantees of any type due to the constantly changing nature of this type of information and running changes in vehicle production. Any person or entity using this information does so at his or its own risk. If you find our instructions are different from your vehicle, or if you have questions, do not continue with your installation. Contact our toll-free technical support for assistance.



Inside...

Page

2	Factory Radio Removal	✓							
3	Receiver Installation	✓							
4	Door Speakers (sedan & wagon)	✓	✓	✓			✓		
5	Rear Speakers (sedan)	✓		✓	✓	✓		✓	✓
6	Rear Speakers (continued)								
		Phillips Screwdriver	Flat Blade Screwdriver	Panel Tool	10mm Socket, Ratchet, & Extension	12mm	Torx T20 Driver	"Stubby" Phillips Screwdriver	Shop Rag (if equipped with manual windows)
Tools Required ▶									

NOTE:

- At this time, no aftermarket antenna is available for this vehicle. A replacement antenna may be purchased from a Subaru dealership.

CRUTCHFIELD™

Copyright 2005 Crutchfield Corporation

050 0026

Factory Radio Removal

1. Set parking brake and disconnect negative battery cable to prevent any electrical short.
2. Open console door. Remove two (2) phillips screws and pull upward on rear portion of **console trim** to remove (see Inset).
3. Pull upward on **shifter trimpanel** and move slightly rearward (see Inset).
4. Remove **ashtray** (or pocket if equipped) and two (2) phillips screws from ashtray cavity.
5. Pull out cupholder. Remove two (2) phillips screws from each side of **cupholder slot**. Pull out entire **cupholder assembly**.
6. Pull **receiver trimpanel** away from dash. Carefully disconnect cigarette lighter connector (if equipped). Remove receiver trimpanel. **Note:** Access to cigarette lighter may be easier by reaching through the ashtray cavity.
7. Remove six (6) phillips screws securing **factory radio/pocket assembly**. Pull out assembly, disconnect and remove.
8. Remove four (4) phillips screws (two on each side) securing factory radio to **factory brackets**. Remove radio and retain screws for installation of replacement receiver.

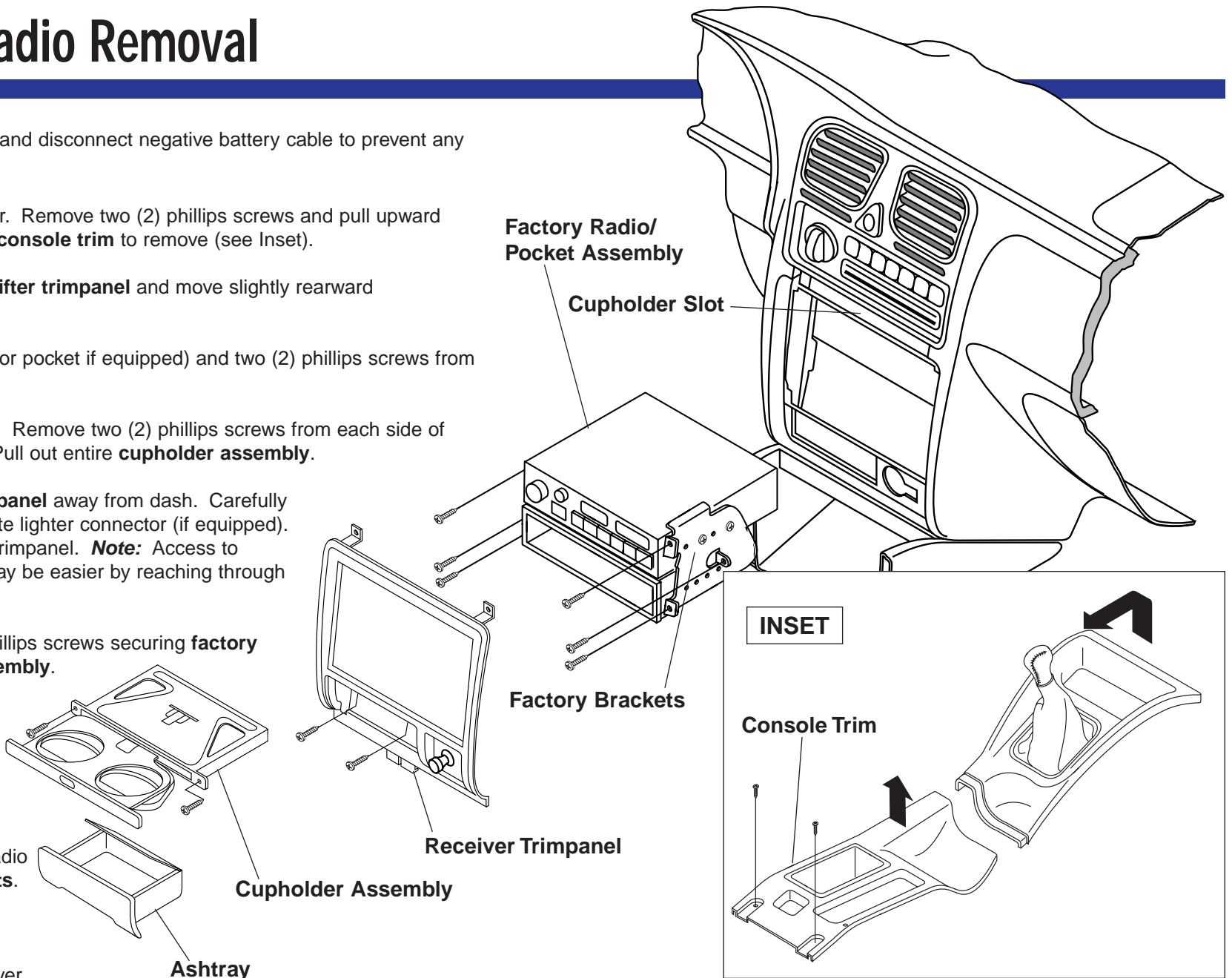

050 0026

ISO-DIN Receiver Installation

NOTES:

Please read first

- *Inspect factory receiver harness connector in vehicle. Ensure that the wiring adaptor received from Crutchfield plugs into the vehicle's connector. If the connector is missing or incorrect, please call our Technical Service Department at 1-800-955-9094.*

1. Connect receiver wiring adaptor to receiver following instructions supplied with adaptor.
2. Remove **DIN sleeve** and **trim ring** from receiver if they are in place (Figure 1). **Note:** These parts will not be used in the ISO-DIN installation.
3. Secure pocket to factory brackets if not already in place. Align holes in sides of replacement receiver with holes in factory side brackets (Figure 2). Secure receiver to brackets using screws previously removed.
4. Hold **receiver assembly** near dash. Connect adaptor harness to factory harness. Plug antenna lead into rear of receiver.
5. Secure assembly to dash using screws previously removed and test operation.
6. Reassemble dash by reversing disassembly steps.

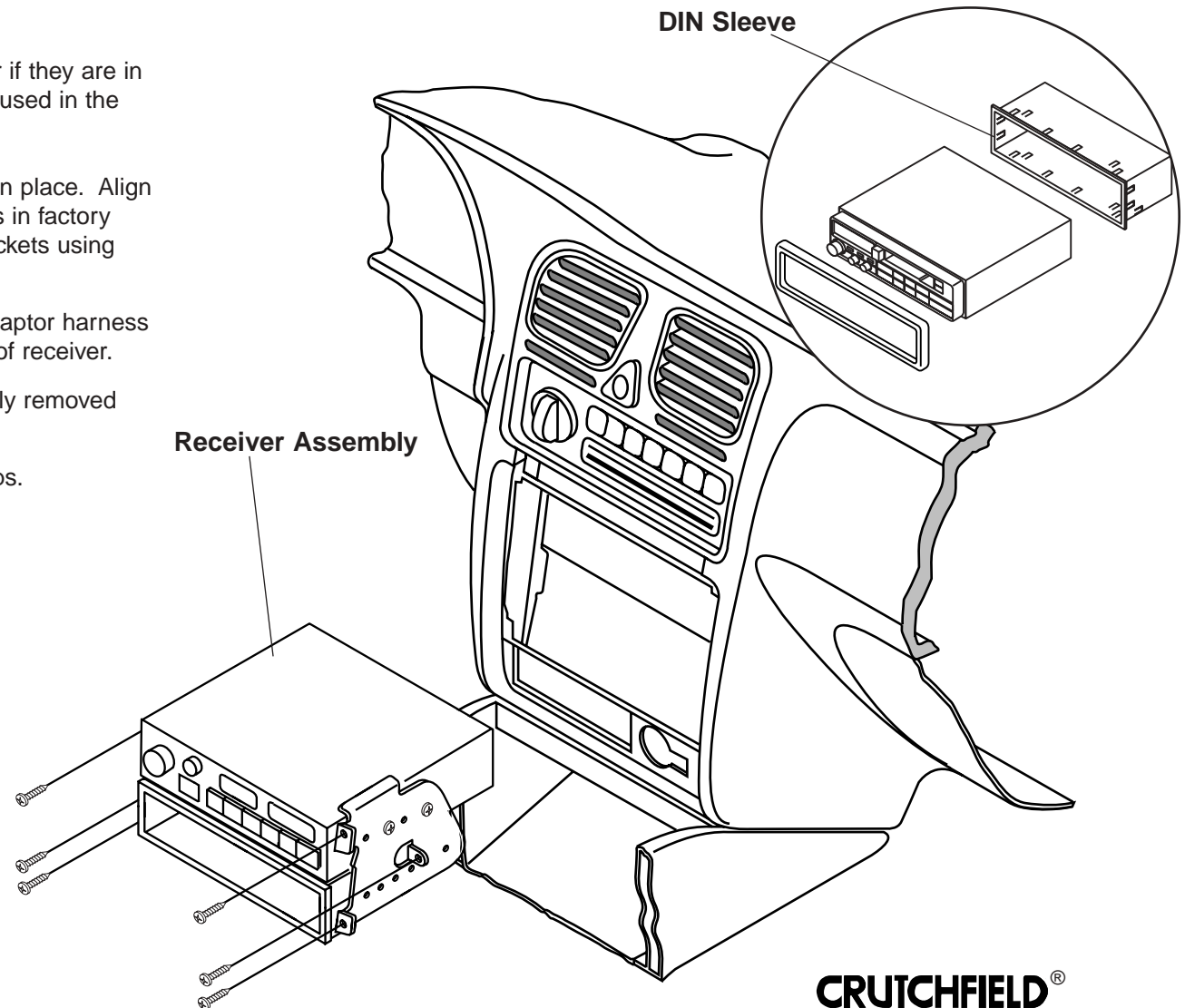
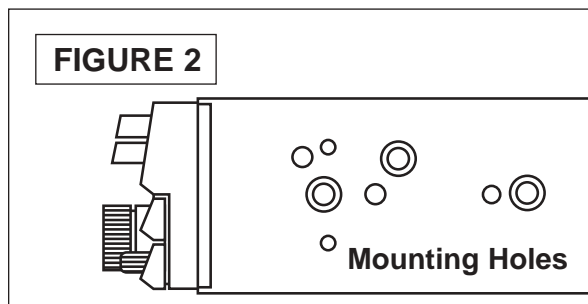

050 0026

Door Speakers (includes rear door speakers for the wagon)

NOTES:

Please read first

- Instructions show factory size speakers only. Cutting, fabricating, or speaker adaptor brackets (not shown) will be required for other speaker sizes.

1. Pry off “sail” (or tweeter) panel. Disconnect tweeter if equipped and remove. **Note:** Rear door panel for the wagon will not have a “sail” panel.
2. Pry open **screw cover** in rear of **door release trim**. Remove phillips screw.
3. Pry out **retaining clip** located at upper front portion of **door panel**. **Note:** Clip is not present on rear door.
4. Pry out screw cover in bottom of armrest and remove phillips screw.
5. **If equipped with power options:** Carefully pry up **switch panel**, disconnect switch and remove.
If equipped with manual windows: Use a shop rag to release “C” clip on rear of crank and remove crank (see Inset).
6. Pry around edges of door panel to release retaining clips. Pull out door release handle and lift panel off window channel. Disconnect electrical connectors to remove panel.
7. Remove three (3) Torx T20 screws securing speaker to **factory bracket**. Pull out speaker, disconnect and remove.
8. Connect speaker wiring adaptor of replacement speaker to vehicle speaker connector.
9. Secure speaker to factory bracket with screws previously removed.
10. Test speaker operation and reinstall door panel by reversing removal steps.

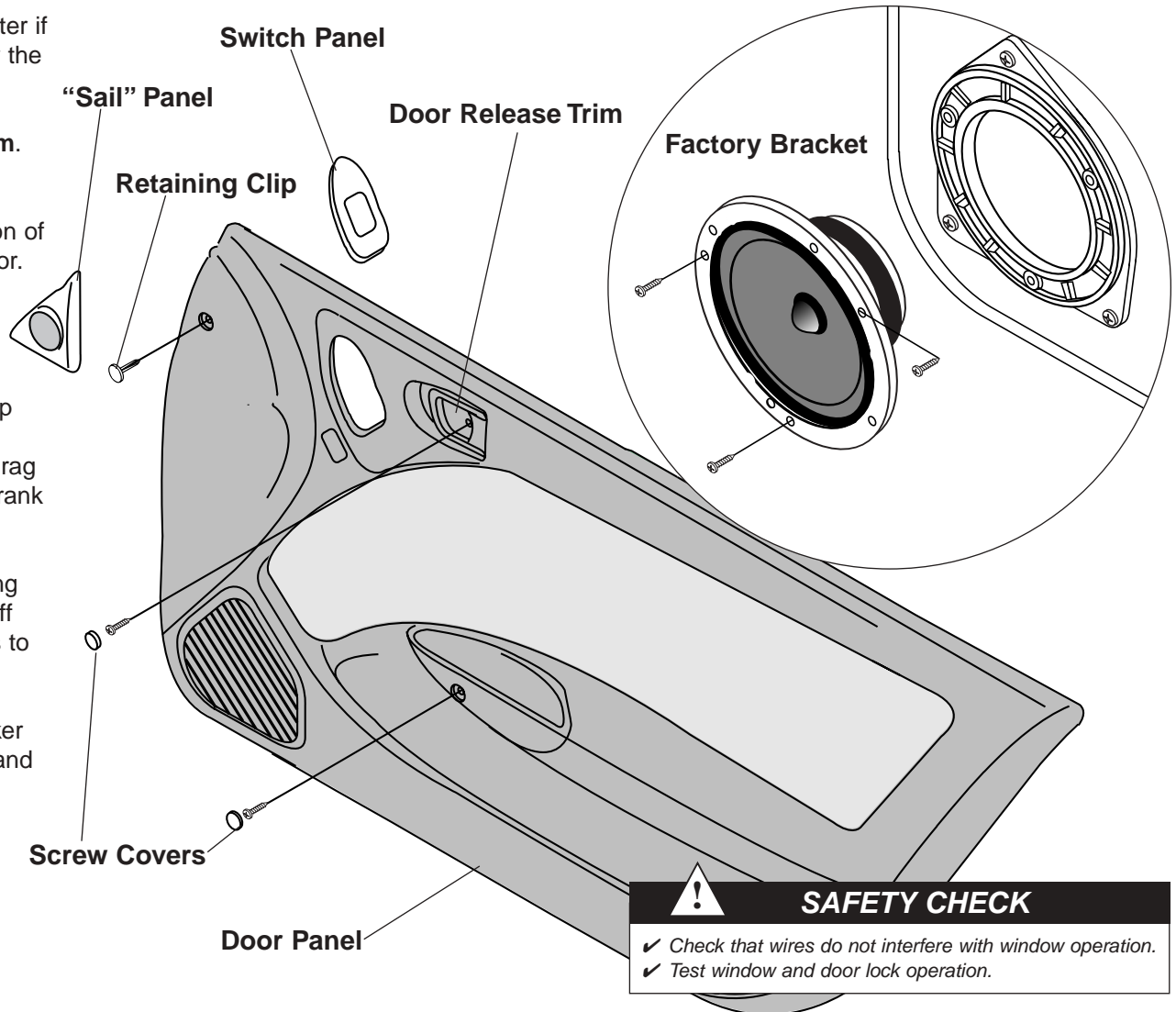

1-800-955-9094
Technical Service

CRUTCHFIELD®

Copyright 2005 Crutchfield Corporation

050 0026

Rear Speakers -- Sedan

NOTES:

Please read first

- Instructions show factory size speakers only. Cutting, fabricating, or speaker adaptor brackets (not shown) will be required for other speaker sizes.

1. Remove two (2) 12mm bolts from below front edge of **seat bottom**. Press center of seat bottom downward to unhook from **seat back**. Remove seat bottom (Figure 1).
2. Remove three (3) 12mm bolts from bottom edge of seat back. Fold seats forward, if equipped with folding seats, and slide seat back upward to remove.
3. If equipped with third brake light: Loosen two (2) 10mm bolts from the bottom of rear deck. Slide **brake light assembly** away from window, disconnect and remove assembly (Figure 2).

Continued on the next page.

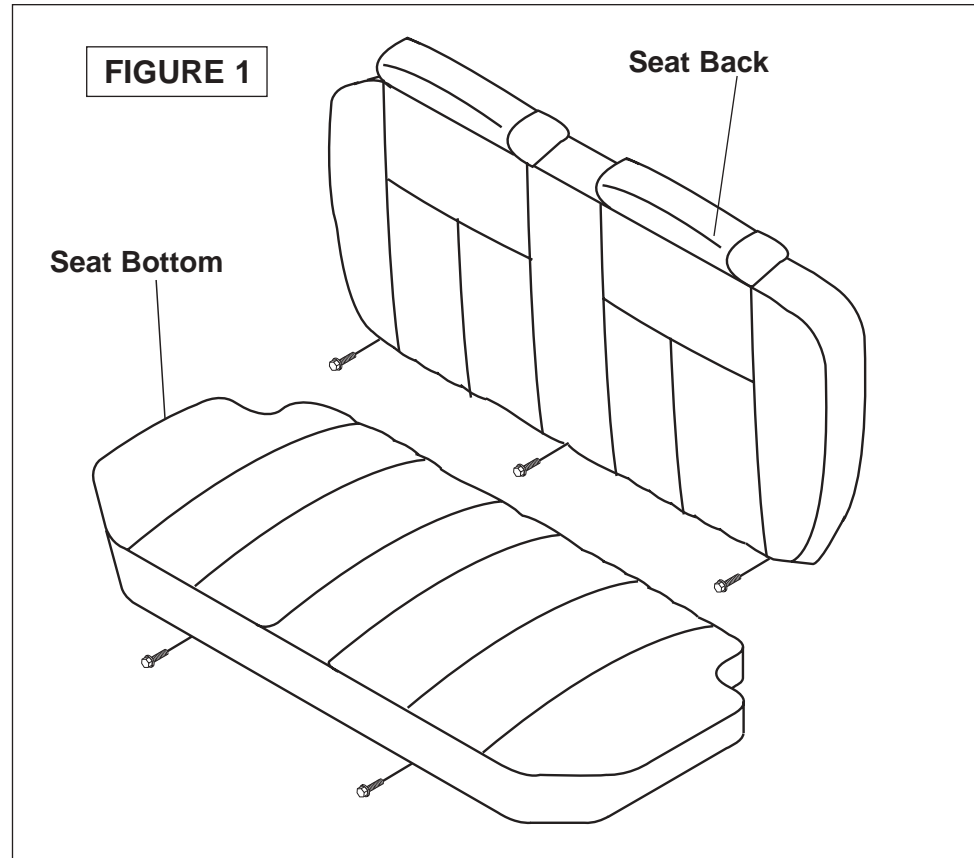

FIGURE 1

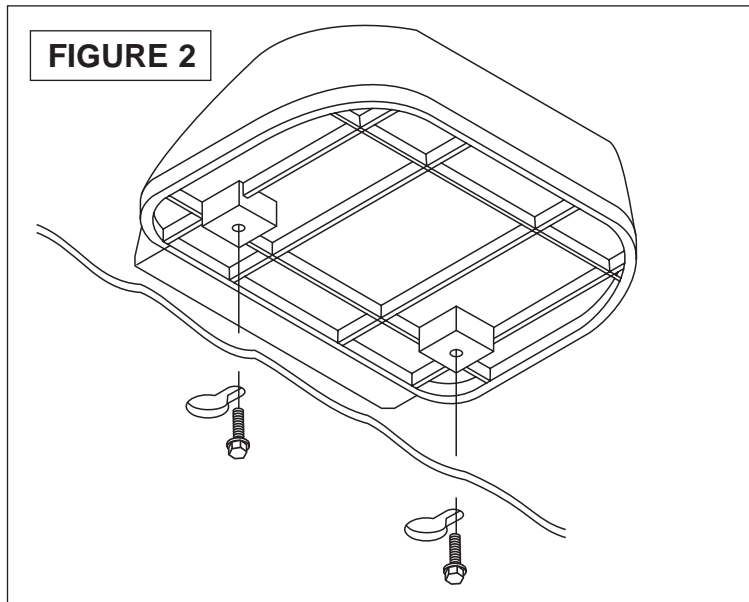

FIGURE 2



SAFETY CHECK

- ✓ Make sure seats and seat belts are secured to manufacturers specifications.
- ✓ Check brake light wiring connection and test operation.



1-800-955-9094
Technical Service

CRUTCHFIELD[®]

Copyright 2005 Crutchfield Corporation

050 0026

Rear Speakers -- Sedan (continued)

4. Pry **rear deck panel** upward to release retaining clips. Bow center of deck panel upward to slide out panel. **Note:** Rear window sealing material sometimes causes panel to be stuck in place. It may be necessary to pull vigorously to remove panel.
5. Remove three (3) phillips screws securing speaker to rear deck. Pull out speaker, disconnect and remove.
6. Connect speaker wiring adaptor and secure replacement speaker to rear deck with screws previously removed.
7. Test speaker for proper operation and reassemble rear of vehicle by reversing removal steps.

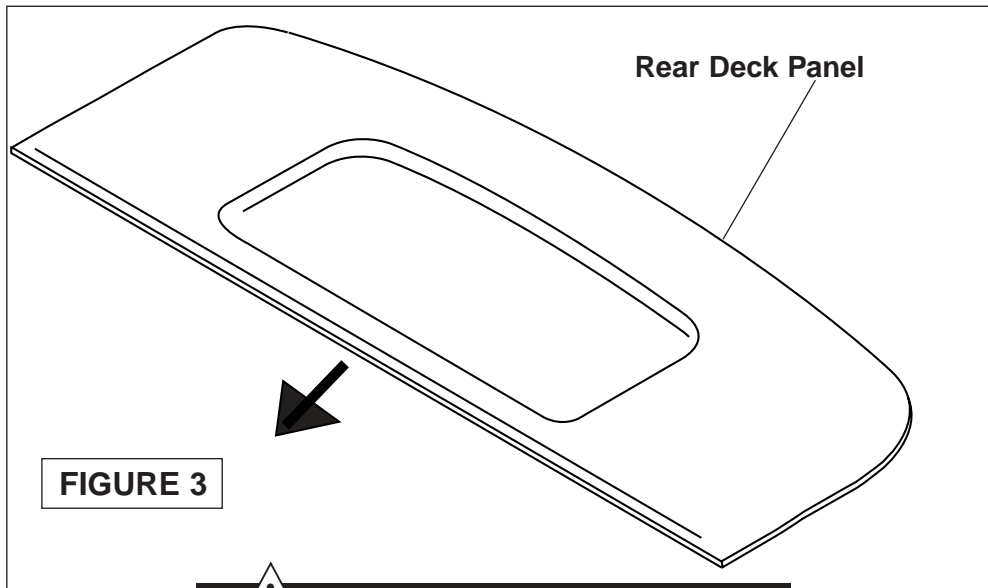

FIGURE 3



SAFETY CHECK

- ✓ Make sure seats and seat belts are secured to manufacturers specifications.
- ✓ Check brake light wiring connection and test operation.

NOTES:

Please read first

- Instructions show factory size speakers only. Cutting, fabricating, or speaker adaptor brackets (not shown) will be required for other speaker sizes.

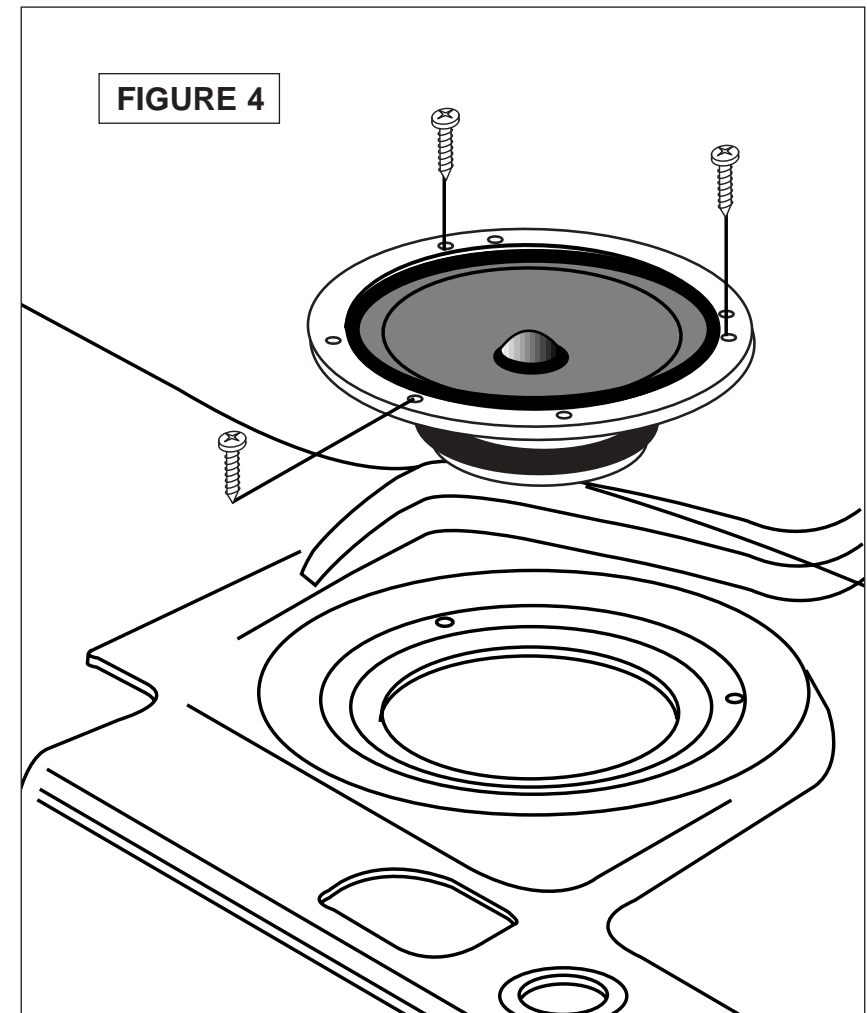

1-800-955-9094
Technical Service

CRUTCHFIELD[®]

Copyright 2005 Crutchfield Corporation